

# CAS TR30



Conveyor  
Application  
Systems



## TR30

### Value

The CAS TR30 is designed with efficiency and value in mind. Our fabricated components are individually powder coated prior to assembly so all surfaces are protected. Many features have been added to make operation as smooth and efficient as possible, for example, cruise control for accurate application such as filling a trench. In addition, the cab provides a controlled environment for the operator which translates into high productivity and comfort.

### Performance

Our new equipment is designed for higher productivity and less maintenance. The CAS high performance conveying system maintains high output while eliminating all chains and sprockets. The TR30 boasts of a very high volume output of 6 tons per minute.

### All Terrain

The rubber tracks on all surfaces allow for cross country maneuverability. The TR30 is part of our special environmental series equipment with low ground pressure for sensitive areas. These factors make this machine extremely mobile and flexible to complete many types of jobs.



# CAS TR30

## Details and Specifications

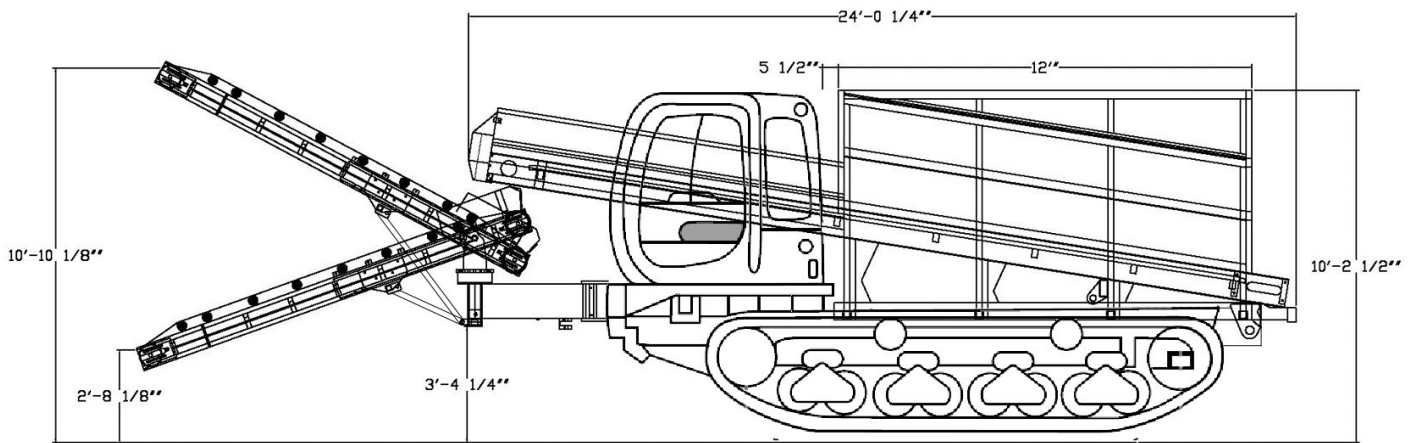

### Chassis

- CAT Engine
- Model: C7
- 6 cylinder
- Displacement: 7.2
- 250 HP @ 2,100 rpm
- Fuel Tank Capacity: 63.4

### Hopper Body

- Steel Box with 10 Gauge Sheeting
- 100% Scam Weld
- Spring Body Mounted
- Powder Coat Finish
- Lined with UHMW

### Feed Conveyor

- Gated
- Fully Exposed 24" wide 330 2-Ply Belt (Reduces Material Bridging)

### Placing Conveyor

- Tube Steel Design
- High Performance Rear Mounted Direct Drive
- Patented Worm Gear Pivot Technology

### Hydraulic System

- Dual Pump Drive mounted 6000, and 3500 PSI rated Hydraulic Piston Pumps
- Pressure & Return Filtration System (10 Micron Absolute Rating)
- Hawe Proportional Valves
- High Pressure Hoses and Fittings

### Standard Equipment

- 7.0" Backup & Passenger Side Safety Cameras
- Hydraulic Activation Safety Switch
- Hydraulically Controlled Deflector Shield
- Travel Cruise Control
- Hall Effect Single Axis Drive Joysticks
- Hall Effect Multi Axis Placing Conveyor Joystick
- Hydraulically activated lift box for maintenance

### Optional Equipment

- Super Shield
- Electric Power Tarp
- Water System with 42 Gallon Tank and Hose Reel
- Tool Box: Aluminum or Stainless Steel
- Vibrator

### Performance

- Max Carrying Capacity: 22,046 lbs.
- Travel Speed - 1st Gear: 0-5.0 mph
- Travel Speed - 2nd Gear: 0-7.5 mph
- Gradeability (unloaded): 30 Degrees
- Ground Pressure: 3.1 psi
- Ground Pressure (loaded): 5.7 psi

## Conveyor Application Systems, LLC

1275 Bailey Hill Road  
Eugene, OR 97402

1-888-279-4227

[www.slingers.com](http://www.slingers.com)



Conveyor  
Application  
Systems