



Conveyor  
Application  
Systems

# CAS RL34



## Reload Conveyor

### Simple

In a matter of minutes, the Reload Conveyor is quickly and safely set up and ready to feed. It unfolds to load the tallest of trucks, which makes it extremely versatile.

### Mobile

Towed behind a standard pickup, the Reload Conveyor's lightweight design is extremely transportable and maneuverable as seen in the picture to the right.

### Functional

The Reload Conveyor is designed for quick loading of material while eliminating contamination of material from dumping on the ground.

### CAS Quality

At CAS we pride ourselves in the quality of all of our equipment. As an example, our fabricated components are individually powder coated prior to assembly so all surfaces are protected. And most important, we stand behind our product with ongoing support and manufacturer's warranty. CAS quality is the CAS difference.



# CAS RL34

## Details and Specifications

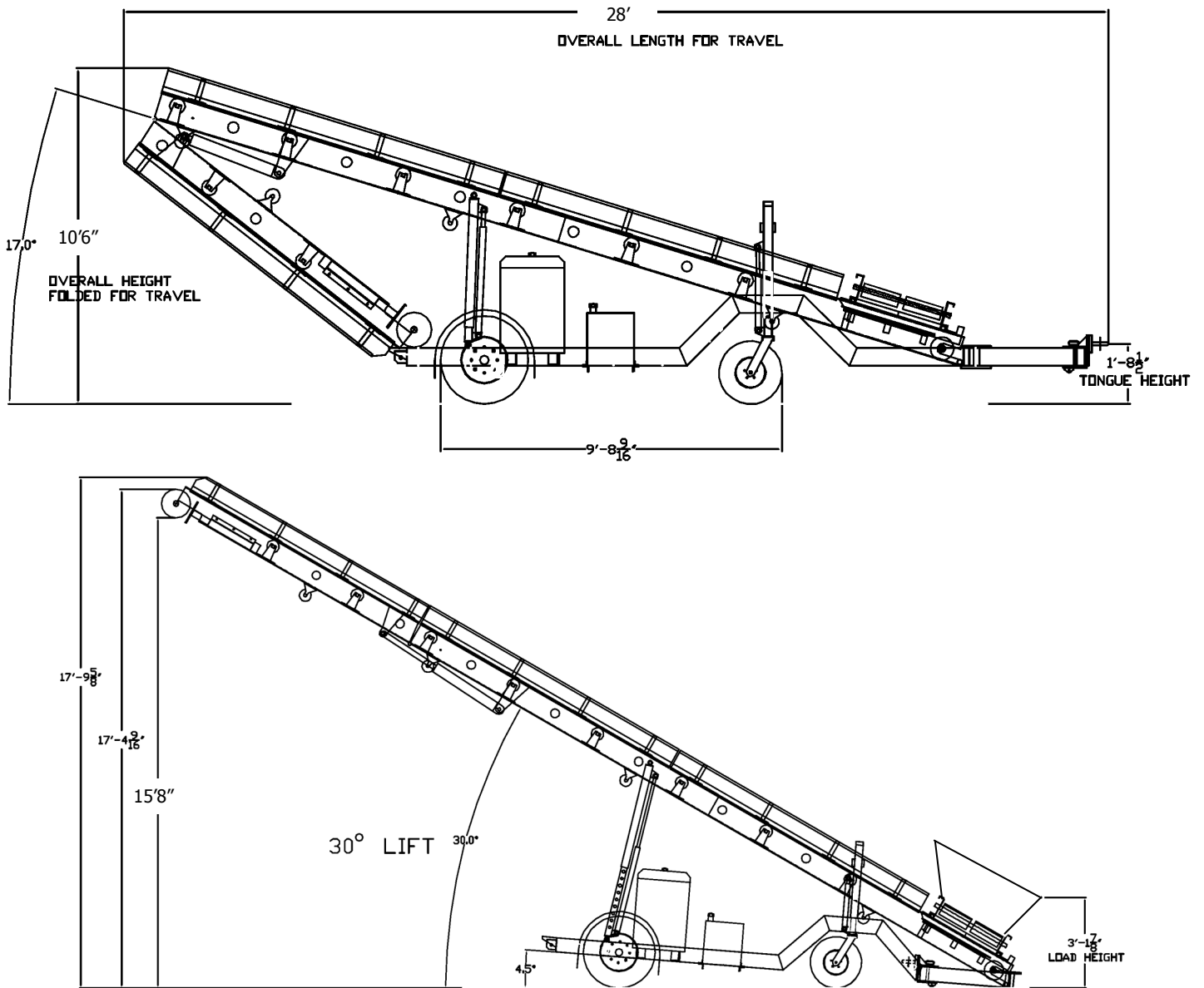

- 67 HP Yanmar Liquid Cooled Diesel Engine
- 36" Feed Belt
- Cross-Feed Hopper Conveyors
- Tow Height: 10'6"
- Extended Hopper Width: 10'6"
- Extended Clearance Height: 15'8"
- Overall Length: 34'
- Tow Weight: 8,750 lbs
- Tow Length: 28'
- Production:
  - 4-6 tons of 1" rock per minute\*
  - 6-10 yards of organic material per minute\*

## Conveyor Application Systems, LLC

1275 Bailey Hill Road  
Eugene, OR 97402

1-888-279-4227

[www.slingers.com](http://www.slingers.com)

\*Production volume varies widely depending upon material



Conveyor  
Application  
Systems